



RF-Router-N

Radio Router

Technical specifications and installation instructions

Part number 60529



elsner

Elsner Elektronik GmbH Control and Automation Technology

Sohlegrund 16

D - 75395 Ostelsheim
Germany

Phone+49 (0) 70 33 / 30 945-0 info@elsner-elektronik.de
Fax +49 (0) 70 33 / 30 945-20 www.elsner-elektronik.de

Technical Service: +49 (0) 70 33 / 30 945-250

1. Description

The **RF-Router-N** routes the radio signals from 16 radio clients to the WS1 and WS1000 Color/Style controllers. As a result, the range of the radio signal is increased.

Due to its construction as an adapter, the RF-Router-N can be used by everyone without having to call an electrician.

Functions:

- Bidirectional routing of the radio signal
- For up to 16 radio clients (devices with radio protocol Elsner RF)
- For controllers WS1 Color, WS1 Style, (KNX) WS1000 Color, (KNX) WS1000 Style (Software 1.708 and higher)

1.0.1. Safety advice



WARNING!

Risk of injury caused by components moved automatically!

If the wireless connection between the control unit and the wireless actuator is interrupted, connected devices can no longer be operated.

- For that reason do not connect drives to the wireless actuator which could be hazardous to human life!

1.1. Technical specifications

Housing	Plastic, black
Protection category	IP 20
Dimensions	approx. 54 x 86 x 80 (W x H x D, mm)
Weight	approx. 175 g
Ambient temperature	Operation -20...+50 °C, storage -55...+70°C
Ambient humidity	max. 95% RH, avoid condensation
Operating voltage	230 V AC (earth-protected plug CEE 7/4)
Output (looped through)	CEE 7/4 socket (for earth-protected plug), loadable with max. 10 A / 230 V AC
Frequency range	868.0...868.6 MHz
Transmission power	max. 25 mW

The product is compliant with the provisions of EU guidelines.

1.2. Deliverables

- Router in housing with integrated socket CEE 7/4.

2. Installation and commissioning

2.1. Installation notes

**DANGER!****Risk to life from live voltage (mains voltage)!**

There are unprotected live components within the device.

- VDE regulations and national regulations are to be followed.
- Ensure that all lines to be assembled are free of voltage and take precautions against accidental switching on.
- Do not use the device if it is damaged.
- Take the device or system out of service and secure it against unintentional use, if it can be assumed, that risk-free operation is no longer guaranteed.

The device is only to be used for its intended purpose. Any improper modification or failure to follow the operating instructions voids any and all warranty and guarantee claims.

After unpacking the device, check it immediately for possible mechanical damage. If it has been damaged in transport, inform the supplier immediately.

The device may only be used as a fixed-site installation; that means only when assembled and after conclusion of all installation and operational start-up tasks and only in the surroundings designated for it.

Elsner Elektronik is not liable for any changes in norms and standards which may occur after publication of these operating instructions.

2.2. Notes on wireless equipment

When planning facilities with devices that communicate via radio, adequate radio reception must be guaranteed. The range of wireless control will be limited by legal regulation and structural circumstances. Avoid sources of interference and obstacles between receiver and transmitter, that could disturb the wireless communication. Those would be for example:

- Walls and ceilings (especially concrete and solar protection glazing).
- Metal surfaces next to the wireless participants (e. g. aluminium construction of a conservatory).
- Other wireless devices and powerful local transmitters (e.g. wireless headphones), which transmit on the same frequency. Please maintain a minimum distance of 30 cm between wireless transmitters for that reason.

2.3. Connection

The radio router is plugged into a mains socket (CEE 7/4). The mains voltage must be 230 V AC / 50 Hz.



Install and use only in dry interior rooms. Avoid condensation.



Do not expose to continuous sun radiation to avoid overheating.
The housing is not UV-resistant.

The **Radio Router N** is taught-in for the controller like a radio actuator. In the menu *System > Installation > Radio connection > RF Router > Status*

other radio clients that have already been taught-in are assigned to the router. Their radio signal is then routed through the **RF-Router-N** if the transmission path is too long for a direct connection.

2.3.1. Radio communication schema

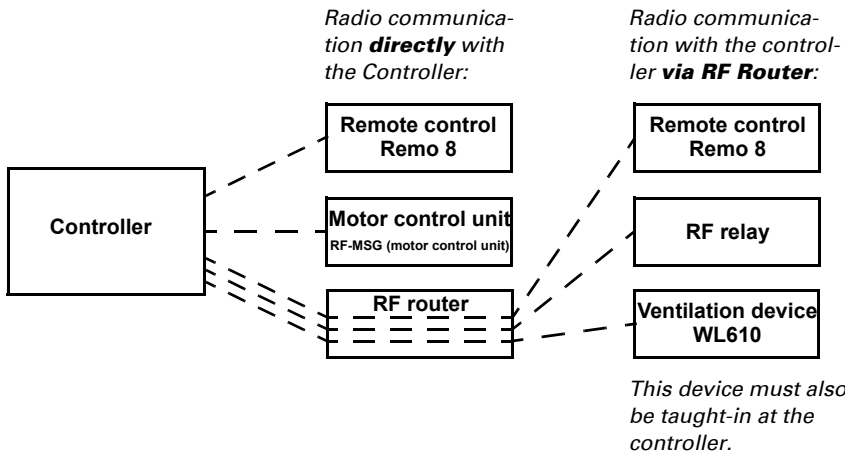

Radio actuators (ventilators, relays, motor control units ...) can only be operated with the remote control Remo 8 *via the controller*. They can *not be additionally* switched directly with the remote control.

2.4. Notes on mounting and commissioning

Device must not be exposed to water (rain). This could result in the electronic being damaged. A relative air humidity of 95% must not be exceeded. Avoid bedewing.

2.5. Establishing a wireless connection

If in the system there are several radio clients operating on one mains line, it is better to teach every radio client separately *before* installation.

1. Put the control unit into teaching mode (observe the corresponding manual/data sheet).
2. Plug in the RF router. The device learns a connection to the control unit on its own 3 seconds after the mains voltage is applied. Only one radio client can be recognised at a time.

Observe the response from the control system ("device taught").

The procedure for assigning radio clients to the router is described in the operating manual for the controller.

3. Disposal

Observe legal regulations and do not dispose of with household waste!

4. Conformity

The radio equipment type **RF-Router-N** complies with Directive 2014/53/EU. The full text of the EU Declaration of Conformity is available at the internet address <https://www.elsner-elektronik.de/en/rf-router.html>