



# **P03/3-Modbus(-GPS)**

## **Weather Stations for Modbus**

---

Item numbers

30146 P03/3-Modbus

30147 P03/3-Modbus-GPS



---

**elsner**

**Manual**

---



---

<b>1. Safety and operating instructions .....</b>	<b>3</b>
<b>2. Description .....</b>	<b>3</b>
<b>3. Commissioning .....</b>	<b>4</b>
3.1. Bus load .....	4
3.2. Setting up bus communication .....	4
3.3. Notes on commissioning .....	5
<b>4. Transfer protocol .....</b>	<b>5</b>
4.1. P03-Modbus request string from the master .....	5
4.2. P03-Modbus output string to the master .....	6

This manual is amended periodically and will be brought into line with new software releases. The change status (software version and date) can be found in the contents footer. If you have a device with a later software version, please check **www.elsner-elektronik.de** in the menu area "Service" to find out whether a more up-to-date version of the manual is available.

## Clarification of signs used in this manual



Safety advice.



Safety advice for working on electrical connections, components, etc.

### **DANGER!**

... indicates an immediately hazardous situation which will lead to death or severe injuries if it is not avoided.

### **WARNING!**

... indicates a potentially hazardous situation which may lead to death or severe injuries if it is not avoided.

### **CAUTION!**

... indicates a potentially hazardous situation which may lead to trivial or minor injuries if it is not avoided.



**ATTENTION!** ... indicates a situation which may lead to damage to property if it is not avoided.

---

# 1. Safety and operating instructions

---



Installation, testing, operational start-up and troubleshooting should only be performed by a qualified electrician.

---



## **CAUTION!** **Live voltage!**

- Inspect the device for damage before installation. Only put undamaged devices into operation.
  - Comply with the locally applicable directives, regulations and provisions for electrical installation.
  - Immediately take the device or system out of service and secure it against unintentional switch-on if risk-free operation is no longer guaranteed.
- 

Use the device exclusively for building automation and observe the operating instructions. Improper use, modifications to the device or failure to observe the operating instructions will invalidate any warranty or guarantee claims.

Operate the device only as a fixed-site installation, i.e. only in assembled condition and after conclusion of all installation and operational start-up tasks, and only in the surroundings designated for it.

Elsner Elektronik is not liable for any changes in norms and standards which may occur after publication of these operating instructions.

---

**For information on installation, maintenance, disposal, scope of delivery and technical data, please refer to the installation instructions.**

---

---

## 2. Description

---

The **P03/3-Modbus** and **P03/3-Modbus-GPS Weather Stations** measure temperature, wind speed and brightness (eastern, southern and western sun) and recognize precipitation.

The **P03/3-Modbus-GPS** additionally receives the UTC signals (Universal Time Coordinated) as well as the site coordinates via an integrated GPS receiver. The direction of the sun (azimuth) as well as its height (elevation) are calculated and indicated, too.

The devices are Modbus slaves with a RS485 interface and a RTU protocol. The Modbus master, such as PC, SPS or MC can read the **P03/3-Modbus(-GPS) Weather Stations** measurement values with "Function 04h (Read Input Register)".

### **Functions:**

- **Brightness measurement** with three separate sensors for east, south and west. Recognition of twilight/dawn

- **Wind measurement:** The wind strength measurement takes place electronically and thus noiselessly and reliably, even during hail, snow and sub-zero temperatures. Even turbulent air and anabatic winds in the vicinity of the weather station are recorded
- **Temperature measurement**
- Heated precipitation sensor (1.2 watts): No false reports as a result of fog or dew. Dries quickly after precipitation has stopped
- **P03/3-Modbus-GPS only:** Integrated GPS receiver. Output of UTC (Universal Time Coordinated), position (degree of longitude and latitude) and position of the sun (azimuth, elevation)

## 3. Commissioning

### 3.1. Bus load

The RS485 transceiver used has 1/8 of a standard RS485 bus load (1/8 unit load) and can manage at least a 2.4 V at 54 Ohm bus load. It can, thus, operate a bus with 32 nodes at standard bus load. If nodes with a lower load than the standard bus load are connected to an RS485 bus, the bus can be operated with more nodes. If, for example, only nodes with 1/8 bus load are connected, up to  $32 \times 8 = 256$  nodes can be connected to the bus.

### 3.2. Setting up bus communication

Fig. 1: detailed view DIP switches

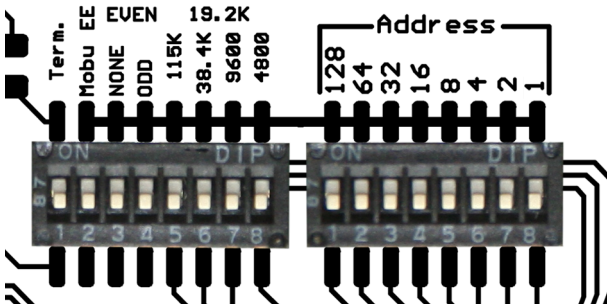

If all DIP switches are in the OFF position (default setting), the following parameters are active:

Address: 1  
 Baud rate: 19,200  
 Parity: Even  
 Termination: Disabled

**Setting of the slave's address:**

The slave address is set with the help of the 8-bit DIP switch "Address". If all switches are in the OFF position, Address 1 is active. Address 0 is reserved for broadcast messages; addresses greater than 247 are not valid.

The coding of the address is binary. For the address 47, you must e.g. set the switches 3, 5, 6, 7 and 8 to ON.

**Interface parameters:**

The interface parameters are set with the help of the second 8-bit DIP switch. If the first 4 switches are in the OFF position, the transfer rate amounts to 19,200 bauds. If one of these switches is set to ON, the corresponding baud rate is applicable.

**Parity:** If the two switches "ODD" and "NONE" are set to OFF, the parity is EVEN. Only "ODD" or "NONE" can switch the corresponding parity check.

**Switch "Mobu EE":** no function.

**Switch "Term.":** bus termination 124 ohms

**3.3. Notes on commissioning**

The correct wind value may only be supplied approximately 60 seconds after the supply voltage has been connected.

**4. Transfer protocol****4.1. P03-Modbus request string from the master**

Byte No.	Variable		Meaning
0	Slave address	xx	
1	Command	04H	Read Input Registers
2	Start address High Byte	xx	Register start address
3	Start address Low Byte	xx	
4	Number of words High Byte	xx	Number of registers to be read
5	Number of words Low Byte	xx	
6	CRC Low Byte	xx	
7	CRC High Byte	xx	

Example query string for reading all data:  
0x01 0x04 0x00 0x00 0x00 0x11 0x30 0x06

## 4.2. P03-Modbus output string to the master

Byte No.	Register address	Variable		Meaning
0		Slave address	xx	
1		Command	04H	Read Input Registers
2		Number of bytes	xx	Master request * 2
3	0	Outdoor temperature	H	with sign, value/10 = temperature xx.x °C
4		Outdoor temperature	L	
5	1	Sun sensor, south	H	1...99 Kilolux
6		Sun sensor, south	L	
7	2	Sun sensor, west	H	1...99 Kilolux
8		Sun sensor, west	L	
9	3	Sun sensor, east	H	1...99 Kilolux
10		Sun sensor, east	L	
11	4	Light	H	0...999 Lux
12		Light	L	
13	5	Wind	H	Value/10 gives wind speed in m/s (metres per second)
14		Wind	L	
15	6	GPS / RTC		1 = GPS; 0 = quartz clock 50 ppm (*)
16		Rain		1 = rain; 0 = no rain
17	7	Day	H	
18		Day	L	Date Day (*)
19	8	Month	H	
20		Month	L	Date Month (*)
21	9	Year	H	
22		Year	L	Date Year (*)
23	10	Hour	H	
24		Hour	L	Time Hour (*)
25	11	Minute	H	
26		Minute	L	Time Minute (*)
27	12	Second	H	
28		Second	L	Time Second (*)
29	13	Azimuth	H	Value/10 = sun position; angle 0.0 ... 359.9 degrees (*)
30		Azimuth	L	
31	14	Elevation	H	Value/10 = sun position; height range +/-90.0 degrees (*)
32		Elevation	L	
33	15	Degree of longitude	H	Value/100 +/- xxx.xx°; + = east / - = west (*)
34		Degree of longitude	L	



Byte No.	Register address	Variable		Meaning
35	16	Degree of latitude	H	Value/100 +/- xxx.xx°; + = north / - = south (*)
36		Degree of latitude	L	
37	CRC		L	
38	CRC		H	

**(\*) Only available with version P03/3-Modbus-GPS (with GPS module)**

Negative values are represented in the two's complement notation.

Time indicated as: UTC (Coordinated Universal Time).

## Questions about the product?

---

You can reach the technical service of Elsner Elektronik under  
**Tel. +49 (0) 70 33 / 30 945-250** or  
**service@elsner-elektronik.de**

We need the following information to process your service request:

- Type of appliance (model name or item number)
- Description of the problem
- Serial number or software version
- Source of supply (dealer/installer who bought the device from Elsner Elektronik)

---

**elsner**

**Elsner Elektronik GmbH** Control and Automation Engineering

Sohlengrund 16  
75395 Ostelsheim  
Germany

Phone +49 (0) 70 33 / 30 945-0 info@elsner-elektronik.de  
Fax +49 (0) 70 33 / 30 945-20 www.elsner-elektronik.de

---